

Honda Multi Point Inspection

Item Specs

- 8-1/2" x 11-3/4"
- 2-Part, Carbonless, Snap-Out Form
- Imprint a logo and up to 4 lines of text.



Standard Stock Colors



(All swatches colors are approximate representations.)

Standard Ink Colors (Including an Approximate Pantone Number)



Adobe Swatch Exchange Files for Stock & Ink Colors are available

Art Requirements

This form can be imprinted with a logo and up to 4 lines of text at the imprinted price. Imprint area is approximately 3" wide x 1-3/4" tall.

Manufacturer logos and trademarks are available for exclusive use by authorized dealers only.

Additional Information

Stock Color: White (Part 1) & Canary (Part 2)	Standard Ink Colors: Black, Blue, Red, Green	Non-Standard Ink Colors: NA
Proof Charge: Up to 3 Free	Plate Charge: Yes	Body Printing: No
Screens & Gradients: NA	PMS Match: NA	Bleed: NA

Production Notes (For Internal Use)	
Production: 085 <ul style="list-style-type: none"> • Crash Imprint • InDesign file created using pre-set template. 	







Honda Multi Point Vehicle Inspection Checklist



R/O TAG NUMBER	NEXT SERVICE DUE
VIN	MILEAGE
SERVICE ADVISOR	TECHNICIAN

■ Satisfactory
 ■ May Require Future Attention
 ■ Requires Immediate Attention

Interior/Exterior	Satisfactory	May Require Future Attention	Requires Immediate Attention
Headlights (check high and low beams)/Taillights/Brake lights/Hazard warning lights/Turn signals/Exterior lamps			
Interior light			
Windshield washer spray/Wiper operation/Wiper blades/Windshield condition			
Parking brake			
Horn operation			
Clutch operation (if applicable)			
Micron cabin filter**			

Tire Condition			
Left Front			Right Front
Wear pattern 		Wear pattern 	
Tire tread _____ 32nds	Tire tread _____ 32nds	Tire tread _____ 32nds	
Left Rear			Right Rear
Wear pattern 		Wear pattern 	
Tire tread _____ 32nds	Tire tread _____ 32nds	Tire tread _____ 32nds	
Spare			
			Front tire inflation set to _____ psi
Wear pattern 			Rear tire inflation set to _____ psi
Tire tread _____ 32nds			

Battery Performance (see attached ED-18 printout)	
Good	
Replace	



Brake Condition			
Left Front			Right Front
_____ mms	_____ mms	_____ mms	
Left Rear			Right Rear
_____ mms	_____ mms	_____ mms	
Brakes not inspected on this visit <input type="checkbox"/>			

Under Hood	Satisfactory	May Require Future Attention	Requires Immediate Attention
Check fluid levels: Oil/Coolant/Power steering fluid/Brake fluid*/Windshield washer fluid/Automatic transmission fluid			
Air filter condition **			
External drive belts and radiator hoses			
Hydraulic clutch reservoir fluid (M/T vehicles)			
Under Vehicle			
Brake lines/Hoses/Parking brake cable			
Shock absorbers/Struts/Suspension/Tie rod ends and boots/Steering gear and dust seals			
Exhaust system			
Engine oil and/or fluid leaks			
Drive shaft boots/Constant velocity boots and bands			

Please Indicate Areas of External Damage or Wear

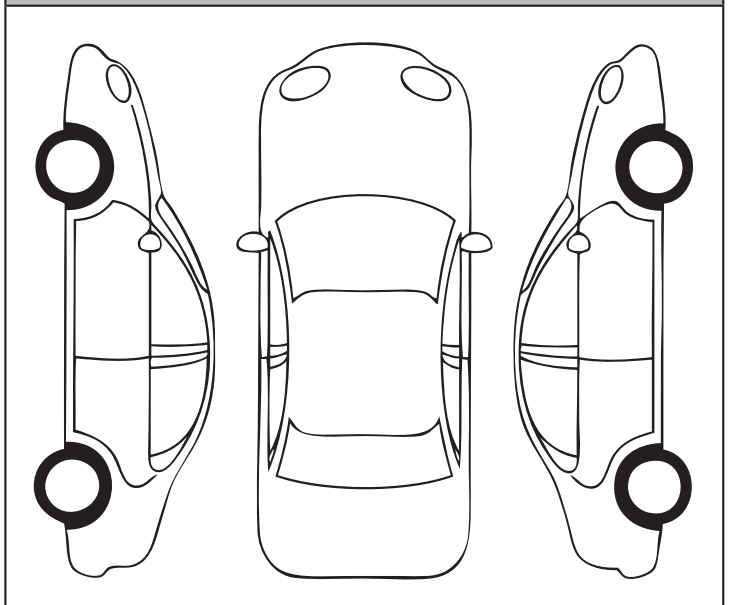

Comments

*Note: Brake fluid NOT filled - fluid level indicate pad wear
 **Refer to maintenance schedule





Honda Multi Point Vehicle Inspection Checklist



R/O TAG NUMBER	NEXT SERVICE DUE
VIN	MILEAGE
SERVICE ADVISOR	TECHNICIAN

Satisfactory
 May Require Future Attention
 Requires Immediate Attention

Interior/Exterior	
Headlights (check high and low beams)/Taillights/Brake lights/Hazard warning lights/Turn signals/Exterior lamps	
Interior light	
Windshield washer spray/Wiper operation/Wiper blades/Windshield condition	
Parking brake	
Horn operation	
Clutch operation (if applicable)	
Micron cabin filter**	

Tire Condition			
Left Front			Right Front
	Wear pattern 	Wear pattern 	
	Tire tread _____ 32nds	Tire tread _____ 32nds	
Left Rear			Right Rear
	Wear pattern 	Wear pattern 	
	Tire tread _____ 32nds	Tire tread _____ 32nds	
Spare		Front tire inflation set to _____ psi Rear tire inflation set to _____ psi	
	Wear pattern 		
	Tire tread _____ 32nds		

Battery Performance (see attached ED-18 printout)	
Good	
Replace	



Under Hood	
Check fluid levels: Oil/Coolant/Power steering fluid/Brake fluid*/Windshield washer fluid/Automatic transmission fluid	
Air filter condition **	
External drive belts and radiator hoses	
Hydraulic clutch reservoir fluid (M/T vehicles)	

Under Vehicle	
Brake lines/Hoses/Parking brake cable	
Shock absorbers/Struts/Suspension/Tie rod ends and boots/Steering gear and dust seals	
Exhaust system	
Engine oil and/or fluid leaks	
Drive shaft boots/Constant velocity boots and bands	

Brake Condition			
Left Front			Right Front
	_____ mms	_____ mms	
Left Rear			Right Rear
	_____ mms	_____ mms	
Brakes not inspected on this visit <input type="checkbox"/>			

Comments

Please Indicate Areas of External Damage or Wear

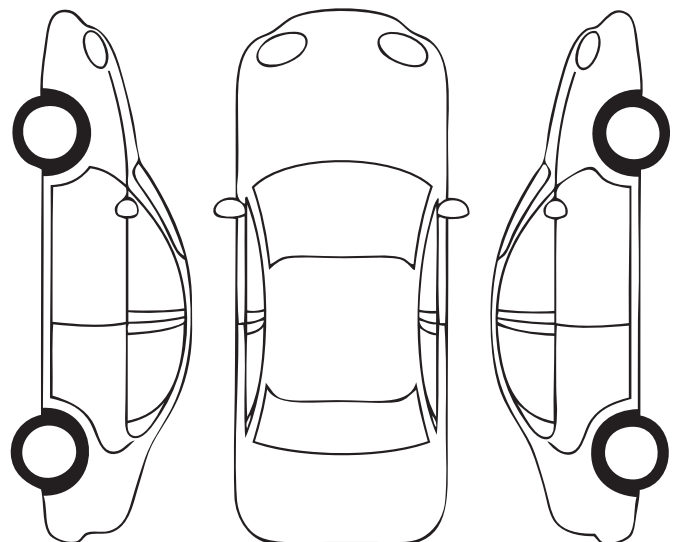

*Note: Brake fluid NOT filled - fluid level indicate pad wear
 **Refer to maintenance schedule